

HONDA
ENGINES

Owner's Manual
GX240·GX270·GX340·GX390

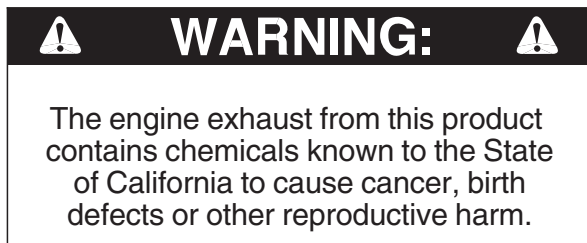



Keep this owner's manual handy, so you can refer to it at any time. This owner's manual is considered a permanent part of the engine and should remain with the engine if resold.

The information and specifications included in this publication were in effect at the time of approval for printing. Illustrations are based on the GX270. Only certain types are equipped for both electric and manual starting. Honda Motor Co., Ltd. reserves the right, however, to discontinue or change specifications or design at any time without notice and without incurring any obligation whatever. No part of this publication may be reproduced without written permission.

INTRODUCTION

Congratulations on your selection of a Honda engine. We are certain you will be pleased with your purchase of one of the finest engines on the market.

We want to help you get the best results from your new engine and to operate it safely. This manual contains the information on how to do that; please read it carefully.

As you read this manual, you will find information preceded by a **NOTICE** symbol. That information is intended to help you avoid damage to your engine, other property, or the environment.

We suggest you read the warranty policy to fully understand its coverage and your responsibilities of ownership. The warranty policy is a separate document that should have been given to you by your dealer.

When your engine needs scheduled maintenance, keep in mind that your Honda servicing dealer is specially trained in servicing Honda engines. Your Honda servicing dealer is dedicated to your satisfaction and will be pleased to answer your questions and concerns.

Best Wishes,
Honda Motor Co., Ltd.

INTRODUCTION

A FEW WORDS ABOUT SAFETY

Your safety and the safety of others is very important. And using this engine safely is an important responsibility.

To help you make informed decisions about safety, we have provided operating procedures and other information on labels and in this manual. This information alerts you to potential hazards that could hurt you or others.

Of course, it is not practical or possible to warn you about all the hazards associated with operating or maintaining an engine. You must use your own good judgment.

You will find important safety information in a variety of forms, including:

- **Safety Messages** — preceded by a safety alert symbol  and one of three signal words, DANGER, WARNING, or CAUTION.

These signal words mean:

 **DANGER**

You WILL be KILLED or SERIOUSLY HURT if you don't follow instructions.

 **WARNING**

You CAN be KILLED or SERIOUSLY HURT if you don't follow instructions.

 **CAUTION**

You CAN be HURT if you don't follow instructions.

- **Safety Headings** — such as *IMPORTANT SAFETY INFORMATION*.
- **Safety Section** — such as *ENGINE SAFETY*.
- **Instructions** — how to use this engine correctly and safely.

This entire book is filled with important safety information — please read it carefully.

CONTENTS

ENGINE SAFETY	5
IMPORTANT SAFETY INFORMATION	5
CONTROLS & FEATURES	7
COMPONENT & CONTROL LOCATIONS	7
CONTROLS	8
Fuel Valve Lever	8
Engine Switch	9
Choke Lever	10
Throttle Lever	11
Recoil Starter Grip	11
FEATURES	12
Oil Alert® System (applicable engine types)	12
Circuit Breaker (applicable types only)	12
BEFORE OPERATION	13
IS YOUR ENGINE READY TO GO?	13
Check the General Condition of the Engine	13
Check the Engine	14
Check the Equipment Powered by This Engine	14
OPERATION	15
SAFE OPERATING PRECAUTIONS	15
STARTING THE ENGINE	15
STOPPING THE ENGINE	19
SETTING ENGINE SPEED	20
SERVICING YOUR ENGINE	21
THE IMPORTANCE OF MAINTENANCE	21
MAINTENANCE SAFETY	22
MAINTENANCE SCHEDULE	23
REFUELING	24
FUEL RECOMMENDATIONS	25
ENGINE OIL LEVEL CHECK	26
ENGINE OIL CHANGE	27
ENGINE OIL RECOMMENDATIONS	28
TRANSMISSION OIL LEVEL CHECK (applicable models)	29
TRANSMISSION OIL CHANGE (2:1 reduction type)	30
AIR FILTER INSPECTION	31
AIR CLEANER SERVICE	32
Dual-Filter-Element Types	32
Oil-Bath & Single-Filter-Element Types	34
Low Profile Types	35

CONTENTS

SERVICING YOUR ENGINE (continued)	
SEDIMENT CUP CLEANING	36
SPARK PLUG SERVICE	37
IDLE SPEED ADJUSTMENT	38
SPARK ARRESTER MAINTENANCE (optional equipment)	39
HELPFUL TIPS & SUGGESTIONS	40
STORING YOUR ENGINE	40
Storage Preparation	40
Storage Precautions	43
Removal From Storage	44
TRANSPORTING	45
TAKING CARE OF UNEXPECTED PROBLEMS	46
ENGINE WILL NOT START	46
ENGINE LACKS POWER	46
FUSE REPLACEMENT (applicable types only)	47
TECHNICAL & CONSUMER INFORMATION	48
TECHNICAL INFORMATION	48
Serial Number Location	48
Battery Connections for Electric Starter (applicable types only)	49
Remote Control Linkage	50
Carburetor Modification for High Altitude	51
Oxygenated Fuels	52
Emission Control System Information	53
Air Index	55
Specifications	56
Wiring Diagrams	58
CONSUMER INFORMATION	59
Honda Publications	59
Warranty Service Information	60
QUICK REFERENCE INFORMATION	Inside back cover

ENGINE SAFETY

IMPORTANT SAFETY INFORMATION

Most accidents with engines can be prevented if you follow all instructions in this manual and on the engine. Some of the most common hazards are discussed below, along with the best way to protect yourself and others.

Owner Responsibilities

- Honda engines are designed to give safe and dependable service if operated according to instructions. Read and understand this owner's manual before operating the engine. Failure to do so could result in personal injury or equipment damage.
- Know how to stop the engine quickly, and understand the operation of all controls. Never permit anyone to operate the engine without proper instructions.
- Do not allow children to operate the engine. Keep children and pets away from the area of operation.

Refuel With Care

Gasoline is extremely flammable, and gasoline vapor can explode. Refuel outdoors, in a well-ventilated area, with the engine stopped. Never smoke near gasoline, and keep other flames and sparks away. Always store gasoline in an approved container. If any fuel is spilled, make sure the area is dry before starting the engine.

Hot Exhaust

- The muffler becomes very hot during operation and remains hot for a while after stopping the engine. Be careful not to touch the muffler while it is hot. Let the engine cool before storing it indoors.
- To prevent fire hazards and to provide adequate ventilation for stationary equipment applications, keep the engine at least 3 feet (1 meter) away from building walls and other equipment during operation. Do not place flammable objects close to the engine.

ENGINE SAFETY

Carbon Monoxide Hazard

Exhaust gas contains poisonous carbon monoxide. Avoid inhalation of exhaust gas. Never run the engine in a closed garage or confined area.

Other Equipment

Review the instructions provided with the equipment powered by this engine for any additional safety precautions that should be observed in conjunction with engine startup, shutdown, operation, or protective apparel that may be needed to operate the equipment.

CONTROLS & FEATURES

COMPONENT & CONTROL LOCATIONS

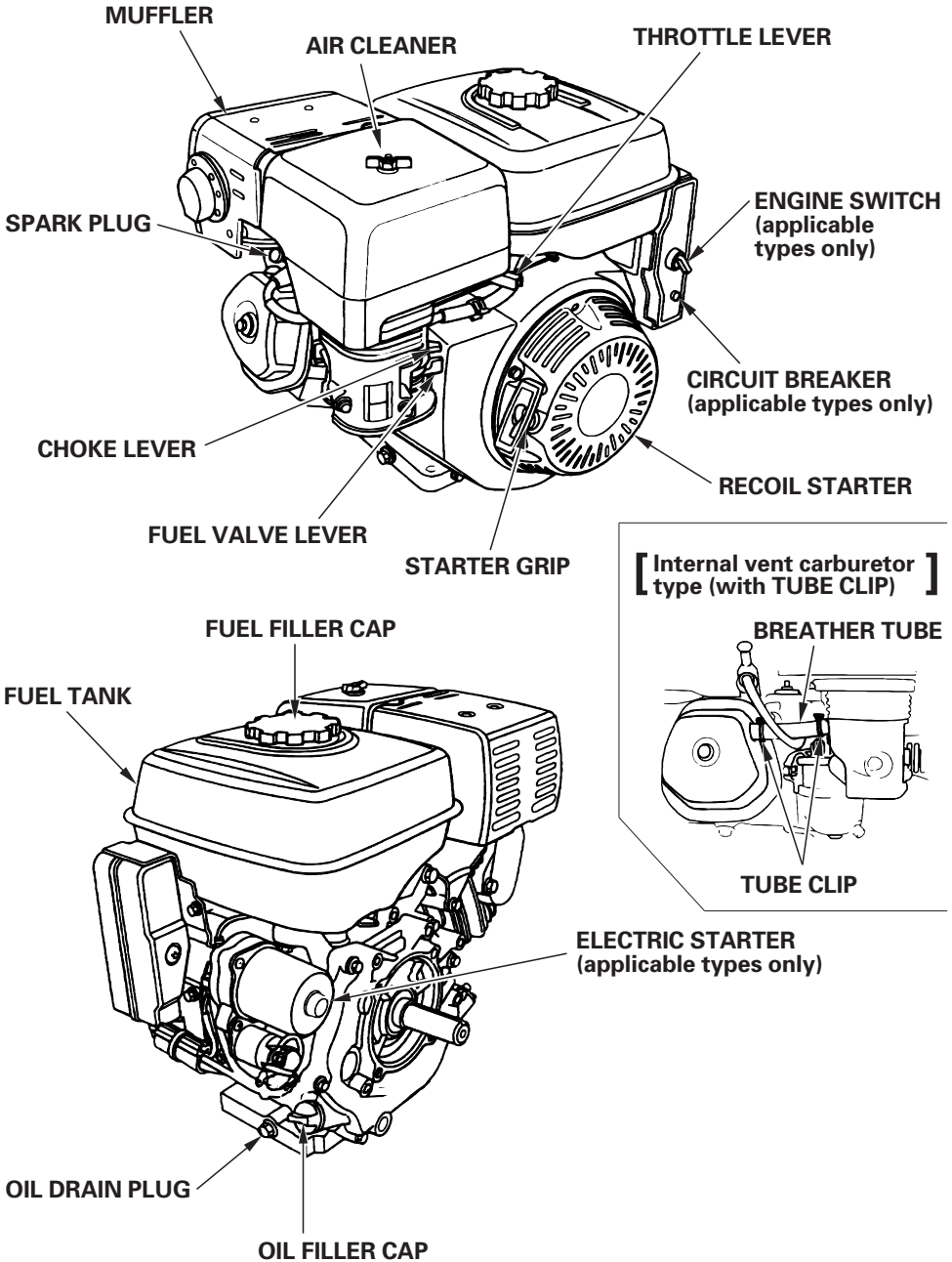

CONTROLS & FEATURES

CONTROLS

Fuel Valve Lever

The fuel valve opens and closes the passage between the fuel tank and the carburetor.

The fuel valve lever must be in the ON position for the engine to run.

When the engine is not in use, leave the fuel valve lever in the OFF position to prevent carburetor flooding and to reduce the possibility of fuel leakage.

FUEL VALVE LEVER

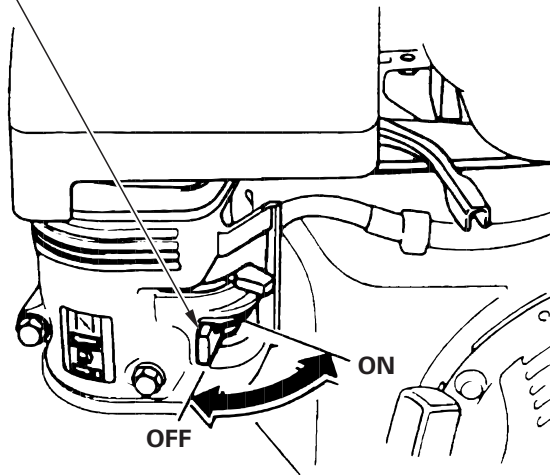

CONTROLS & FEATURES

Engine Switch

The engine switch enables and disables the ignition system.

The engine switch must be in the ON position for the engine to run.

Turning the engine switch to the OFF position stops the engine.

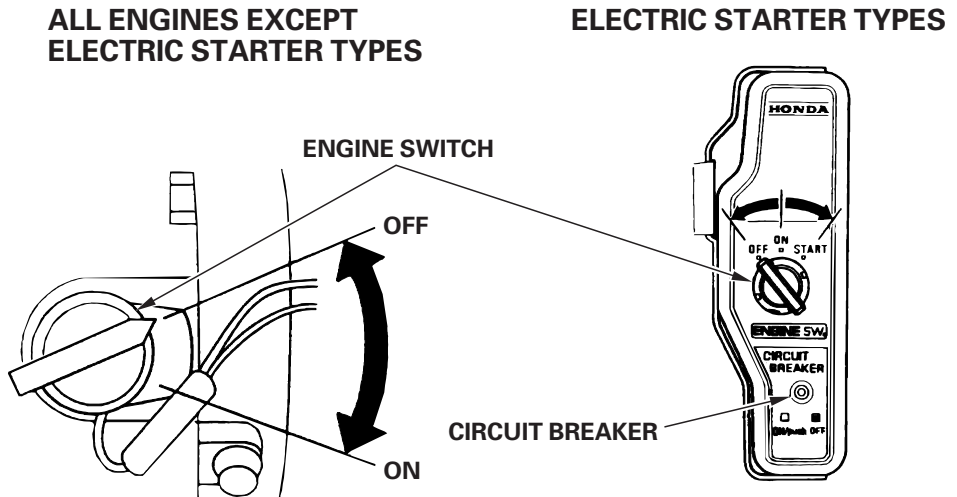

Applicable Types

The engine switch on electric starter types includes a START position for operating the electric starter. The key automatically returns to the ON position when released from the START position.

The circuit breaker, which is located below the key, protects the battery charging circuit (see page 12).

CONTROLS & FEATURES

Choke Lever or Choke Rod (applicable types)

The choke lever or choke rod (applicable types) opens and closes the choke valve in the carburetor.

The CLOSED position enriches the fuel mixture for starting a cold engine.

The OPEN position provides the correct fuel mixture for operation after starting, and for restarting a warm engine.

Some engine applications use a remote-mounted choke control rather than the engine-mounted choke lever shown here.

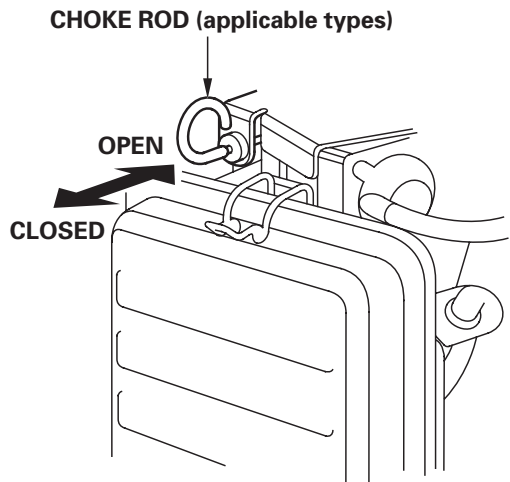
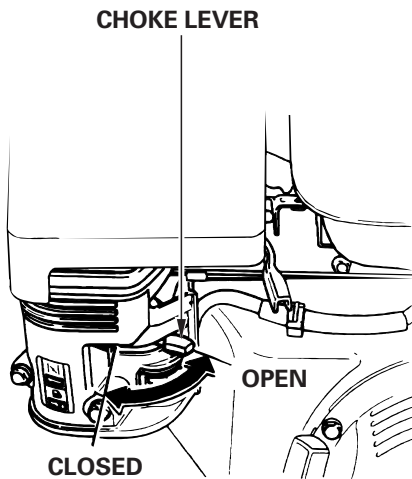

CONTROLS & FEATURES

Throttle Lever

The throttle lever controls engine speed.

Moving the throttle lever in the directions shown makes the engine run faster or slower.

Some engine applications use a remote-mounted throttle control rather than the engine-mounted throttle lever shown here.

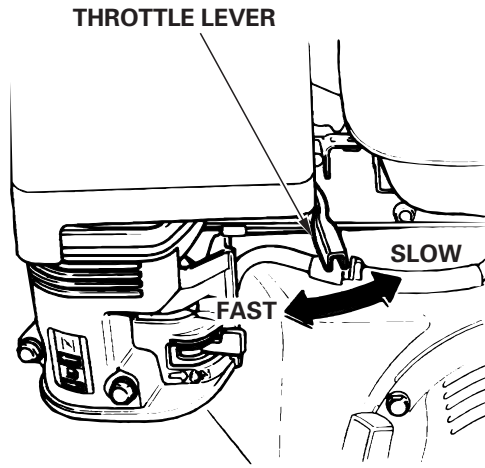

Recoil Starter Grip

Pulling the starter grip operates the recoil starter to crank the engine.

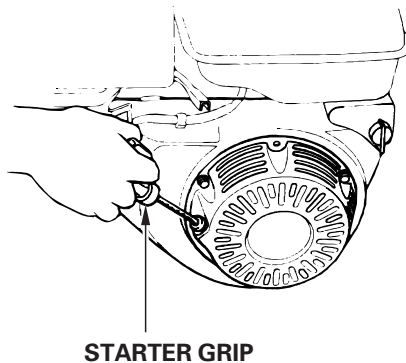

CONTROLS & FEATURES

FEATURES

Oil Alert® System (applicable engine types)

The Oil Alert® system is designed to prevent engine damage caused by an insufficient amount of oil in the crankcase. Before the oil level in the crankcase can fall below a safe limit, the Oil Alert® system will automatically stop the engine (the ignition switch will remain in the ON position).

If the engine stops and will not restart, check the engine oil level (page 26) before troubleshooting in other areas.

Circuit Breaker (applicable types only)

The circuit breaker protects the battery charging circuit. A short circuit, or a battery connected with reverse polarity, will trip the circuit breaker.

The green indicator inside the circuit breaker will pop out to show that the circuit breaker has switched off. If this occurs, determine the cause of the problem, and correct it before resetting the circuit breaker.

Push the circuit breaker button to reset.

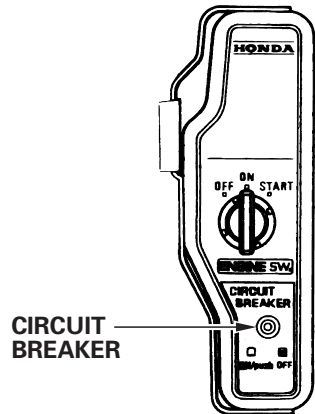

BEFORE OPERATION

IS YOUR ENGINE READY TO GO?

For your safety, and to maximize the service life of your equipment, it is very important to take a few moments before you operate the engine to check its condition. Be sure to take care of any problem you find, or have your servicing dealer correct it, before you operate the engine.

WARNING

Improperly maintaining this engine, or failing to correct a problem before operation, could cause a malfunction in which you could be seriously injured.

Always perform a preoperation inspection before each operation, and correct any problem.

Before beginning your preoperation checks, be sure the engine is level and the engine switch is in the OFF position.

Check the General Condition of the Engine

- Look around and underneath the engine for signs of oil or gasoline leaks.
- Remove any excessive dirt or debris, especially around the muffler and recoil starter.
- Look for signs of damage.
- Check that all shields and covers are in place, and all nuts, bolts, and screws are tightened.

BEFORE OPERATION

Check the Engine

- Check the engine oil level (see page 26). Running the engine with a low oil level can cause engine damage.

The Oil Alert® system (applicable engine types) will automatically stop the engine before the oil level falls below safe limits. However, to avoid the inconvenience of an unexpected shutdown, always check the engine oil level before startup.

- Check the transmission oil level on applicable engine types (see page 29). Oil is essential to transmission operation and long life.
- Check the air filter (see page 31). A dirty air filter will restrict air flow to the carburetor, reducing engine performance.
- Check the fuel level. Starting with a full tank will help to eliminate or reduce operating interruptions for refueling.

Check the Equipment Powered by This Engine

Review the instructions provided with the equipment powered by this engine for any precautions and procedures that should be followed before engine startup.

OPERATION

SAFE OPERATING PRECAUTIONS

Before operating the engine for the first time, please review the *IMPORTANT SAFETY INFORMATION* on page 5 and the chapter titled *BEFORE OPERATION*.

⚠ WARNING

Carbon monoxide gas is toxic.
Breathing it can cause
unconsciousness and even kill you.

Avoid any areas or actions that
expose you to carbon monoxide.

Review the instructions provided with the equipment powered by this engine for any safety precautions that should be observed in conjunction with engine startup, shutdown, or operation.

STARTING THE ENGINE

1. Move the fuel valve lever to the ON position.

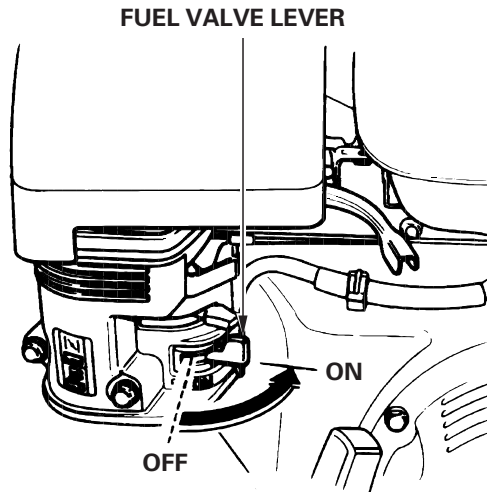

OPERATION

2. To start a cold engine, move the choke lever or choke rod (applicable types) to the CLOSED position.

To restart a warm engine, leave the choke lever in the OPEN position.

Some engine applications use a remote-mounted choke control rather than the engine-mounted choke lever shown here.

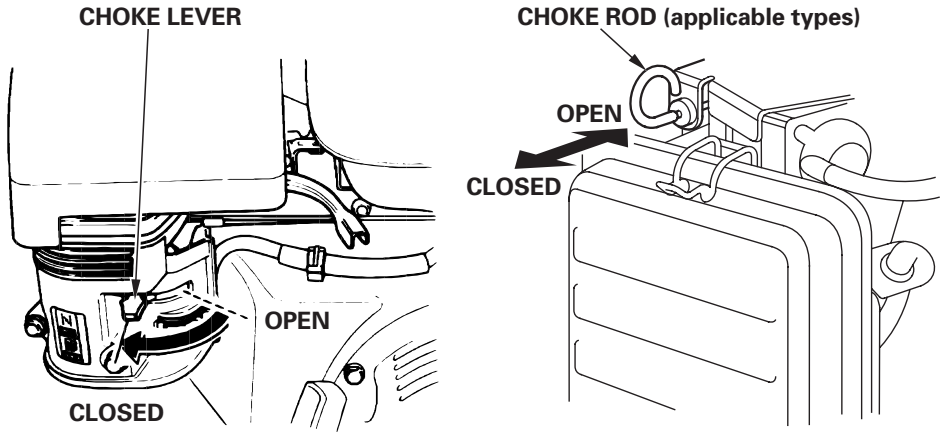

3. Move the throttle lever away from the SLOW position, about 1/3 of the way toward the FAST position.

Some engine applications use a remote-mounted throttle control rather than the engine-mounted throttle lever shown here.

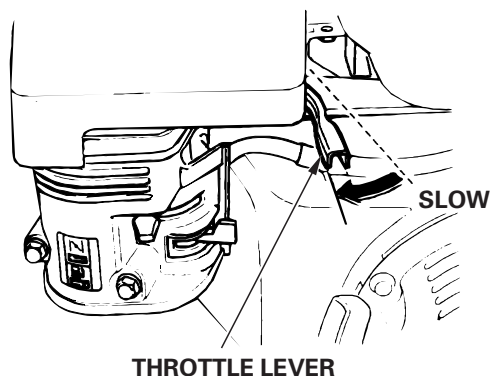

4. Turn the engine switch to the ON position.

ALL ENGINES EXCEPT ELECTRIC STARTER TYPES

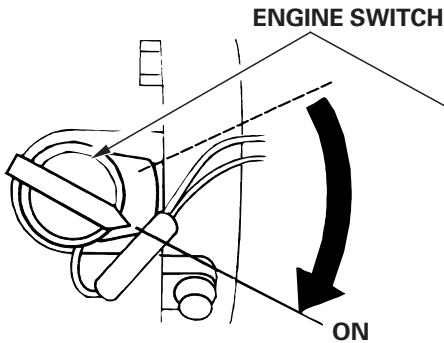

ELECTRIC STARTER TYPES

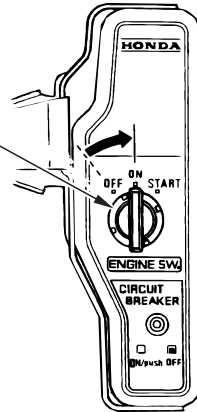

5. Operate the starter.

RECOIL STARTER (all engine types):

Pull the starter grip lightly until you feel resistance, then pull briskly. Return the starter grip gently.

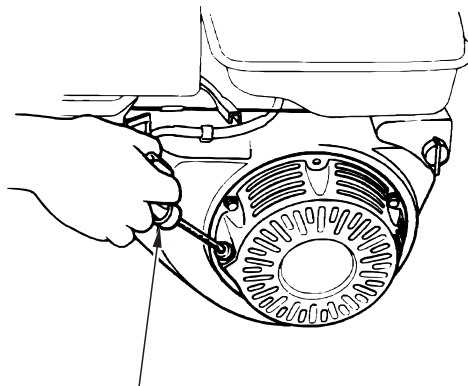

STARTER GRIP

OPERATION

ELECTRIC STARTER (applicable types only):

Turn the key to the **START** position, and hold it there until the engine starts.

If the engine fails to start within 5 seconds, release the key, and wait at least 10 seconds before operating the starter again.

NOTICE

Using the electric starter for more than 5 seconds at a time will overheat the starter motor and can damage it.

When the engine starts, release the key, allowing it to return to the **ON** position.

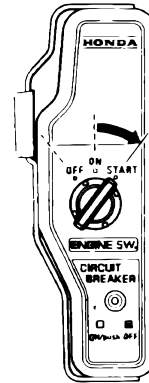

ENGINE SWITCH
(applicable types only)

6. If the choke lever or choke rod (applicable types) has been moved to the **CLOSED** position to start the engine, gradually move it to the **OPEN** position as the engine warms up.

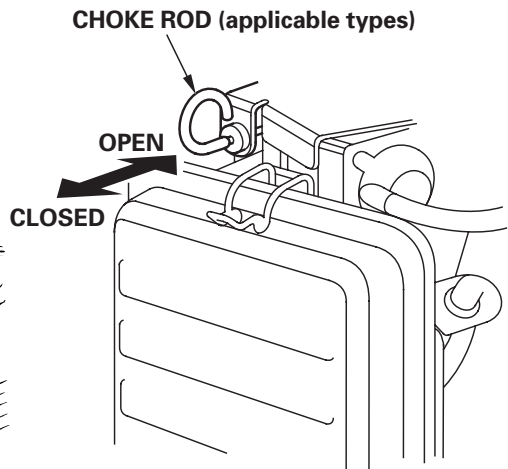
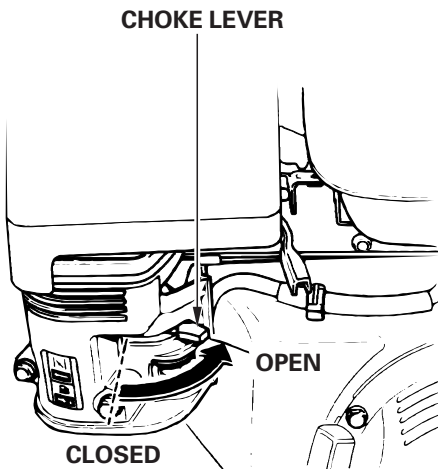

STOPPING THE ENGINE

To stop the engine in an emergency, simply turn the engine switch to the OFF position. Under normal conditions, use the following procedure.

1. Move the throttle lever to the SLOW position.

Some engine applications use a remote-mounted throttle control rather than the engine-mounted throttle lever shown here.

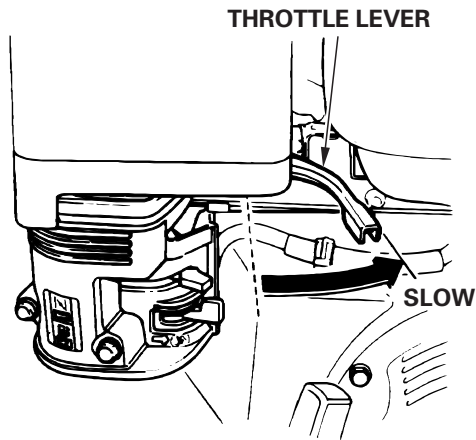

2. Turn the engine switch to the OFF position.

ALL ENGINES EXCEPT ELECTRIC STARTER TYPES

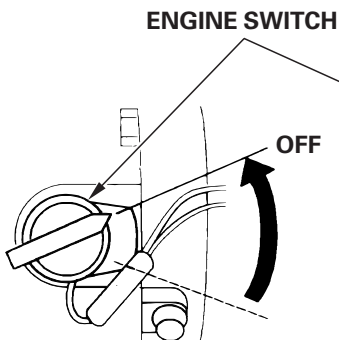

ELECTRIC STARTER TYPES

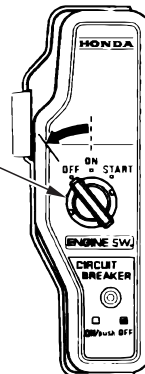

OPERATION

3. Turn the fuel valve lever to the OFF position.

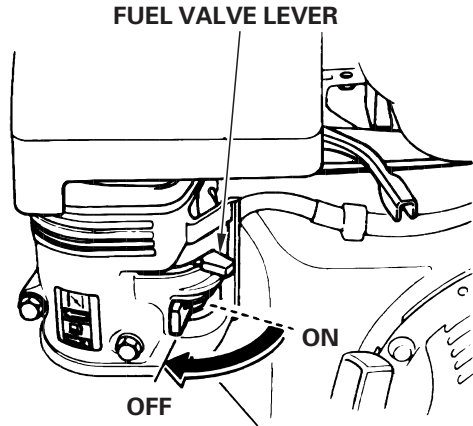

SETTING ENGINE SPEED

Position the throttle lever for the desired engine speed.

Some engine applications use a remote-mounted throttle control rather than the engine-mounted throttle lever shown here.

For engine speed recommendations, refer to the instructions provided with the equipment powered by this engine.

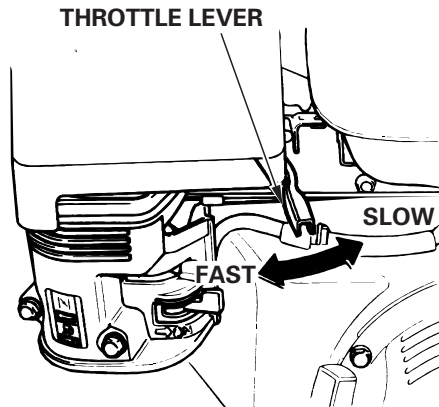

SERVICING YOUR ENGINE

THE IMPORTANCE OF MAINTENANCE

Good maintenance is essential for safe, economical, and trouble-free operation. It will also help reduce air pollution.

WARNING

Improperly maintaining this engine, or failure to correct a problem before operation, can cause a malfunction in which you can be seriously hurt or killed.

Always follow the inspection and maintenance recommendations and schedules in this owner's manual.

To help you properly care for your engine, the following pages include a maintenance schedule, routine inspection procedures, and simple maintenance procedures using basic hand tools. Other service tasks that are more difficult, or require special tools, are best handled by professionals and are normally performed by a Honda technician or other qualified mechanic.

The maintenance schedule applies to normal operating conditions. If you operate your engine under unusual conditions, such as sustained high-load or high-temperature operation, or use in unusually wet or dusty conditions, consult your servicing dealer for recommendations applicable to your individual needs and use.

Maintenance, replacement or repair of emission control devices and systems may be done by any engine repair establishment or individual, using parts that are "certified" to EPA standards.

SERVICING YOUR ENGINE

MAINTENANCE SAFETY

Some of the most important safety precautions follow. However, we cannot warn you of every conceivable hazard that can arise in performing maintenance. Only you can decide whether or not you should perform a given task.

WARNING

Failure to properly follow maintenance instructions and precautions can cause you to be seriously hurt or killed.

Always follow the procedures and precautions in the owner's manual.

Safety Precautions

- Make sure the engine is off before you begin any maintenance or repairs. This will eliminate several potential hazards:
 - **Carbon monoxide poisoning from engine exhaust.**
Be sure there is adequate ventilation whenever you operate the engine.
 - **Burns from hot parts.**
Let the engine and exhaust system cool before touching.
 - **Injury from moving parts.**
Do not run the engine unless instructed to do so.
- Read the instructions before you begin, and make sure you have the tools and skills required.
- To reduce the possibility of fire or explosion, be careful when working around gasoline. Use only a nonflammable solvent, not gasoline, to clean parts. Keep cigarettes, sparks and flames away from all fuel-related parts.

Remember that your servicing dealer knows your engine best and is fully equipped to maintain and repair it.

To ensure the best quality and reliability, use only new, genuine Honda parts or their equivalents for repair and replacement.

SERVICING YOUR ENGINE

MAINTENANCE SCHEDULE

REGULAR SERVICE PERIOD (3)			Each use	First month or 20 Hrs.	Every 3 months or 50 Hrs.	Every 6 months or 100 Hrs.	Every year or 300 Hrs.	Refer to page
ITEM	Perform at every indicated month or operating hour interval, whichever comes first.							
•	Engine oil	Check level	<input type="radio"/>					26
		Change		<input type="radio"/>		<input type="radio"/>		27
•	Reduction gear oil (applicable types)	Check level	<input type="radio"/>					29
		Change		<input type="radio"/>		<input type="radio"/>		30
•	Air filter	Check	<input type="radio"/>					31
		Clean			<input type="radio"/> (1)	<input type="radio"/> * (1)		32
		Replace					<input type="radio"/> * * *	
•	Sediment cup	Clean				<input type="radio"/>		36
•	Spark plug	Check-adjust				<input type="radio"/>		37
		Replace					<input type="radio"/>	
	Spark arrester (optional parts)	Clean				<input type="radio"/>		39
•	Idle speed	Check-adjust					<input type="radio"/> (2)	38
•	Valve clearance	Check-adjust					<input type="radio"/> (2)	—
•	Combustion chamber	Clean	After every 500 Hrs. (2)					—
•	Fuel tank & filter	Clean				<input type="radio"/> (2)		—
•	Fuel tube	Check	Every 2 years (Replace if necessary) (2)					—

• Emission-related items.

* Internal vent carburetor (See page 7) with dual element type only. (Cyclone type every 6 months or 150 hours.)

* * Replace paper element type only. Cyclone type every 2 years or 600 hours.

(1) Service more frequently when used in dusty areas.

(2) These items should be serviced by your servicing dealer, unless you have the proper tools and are mechanically proficient. Refer to Honda shop manual for service procedures.

(3) For commercial use, log hours of operation to determine proper maintenance intervals.

SERVICING YOUR ENGINE

REFUELING

With the engine stopped and on a level surface, remove the fuel tank cap and check the fuel level. Refill the tank if the fuel level is low.

⚠ WARNING

Gasoline is highly flammable and explosive.

You can be burned or seriously injured when handling fuel.

- Stop the engine and keep heat, sparks, and flame away.
- Handle fuel only outdoors.
- Wipe up spills immediately.

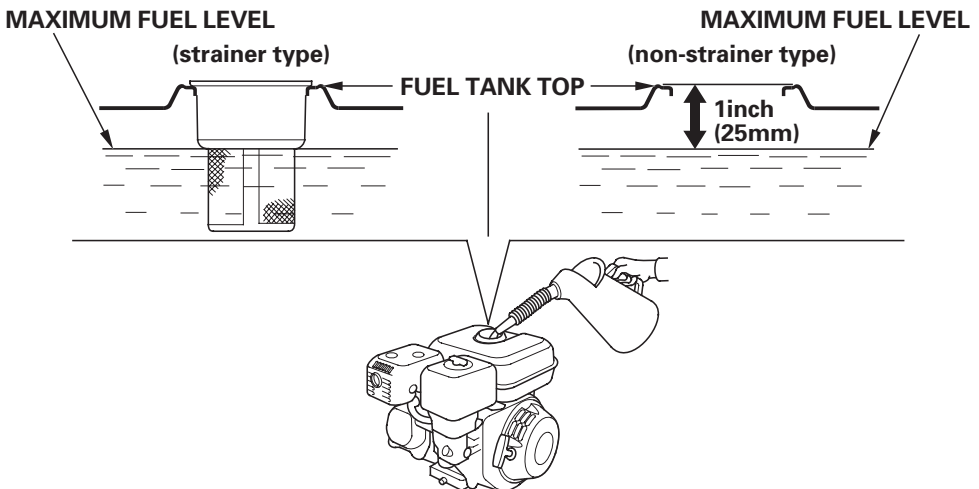

Refuel in a well-ventilated area before starting the engine. If the engine has been running, allow it to cool. Refuel carefully to avoid spilling fuel. Do not fill the fuel tank completely. Fill tank to approximately 1 inch (25 mm) below the top of the fuel tank to allow for fuel expansion. It may be necessary to lower the fuel level depending on operating conditions. After refueling, tighten the fuel tank cap securely.

SERVICING YOUR ENGINE

Never refuel the engine inside a building where gasoline fumes may reach flames or sparks. Keep gasoline away from appliance pilot lights, barbecues, electric appliances, power tools, etc.

Spilled fuel is not only a fire hazard, it causes environmental damage. Wipe up spills immediately.

NOTICE

Fuel can damage paint and plastic. Be careful not to spill fuel when filling your fuel tank. Damage caused by spilled fuel is not covered under warranty.

FUEL RECOMMENDATIONS

Use unleaded gasoline with a pump octane rating of 86 or higher.

These engines are certified to operate on unleaded gasoline. Unleaded gasoline produces fewer engine and spark plug deposits and extends exhaust system life.

Never use stale or contaminated gasoline or an oil/gasoline mixture. Avoid getting dirt or water in the fuel tank.

Occasionally you may hear a light “spark knock” or “pinging” (metallic rapping noise) while operating under heavy loads. This is no cause for concern.

If spark knock or pinging occurs at a steady engine speed, under normal load, change brands of gasoline. If spark knock or pinging persists, see an authorized Honda servicing dealer.

NOTICE

Running the engine with persistent spark knock or pinging can cause engine damage.

Running the engine with persistent spark knock or pinging is considered misuse, and the Distributor’s Limited Warranty does not cover parts damaged by misuse.

SERVICING YOUR ENGINE

ENGINE OIL LEVEL CHECK

Check the engine oil level with the engine stopped and in a level position.

1. Remove the filler cap/dipstick and wipe it clean.
2. Insert and remove the dipstick without screwing it into the filler neck. Check the oil level shown on the dipstick.
3. If the oil level is low, fill to the edge of the oil filler hole with the recommended oil (see page 28).
4. Screw in the filler cap/dipstick securely.

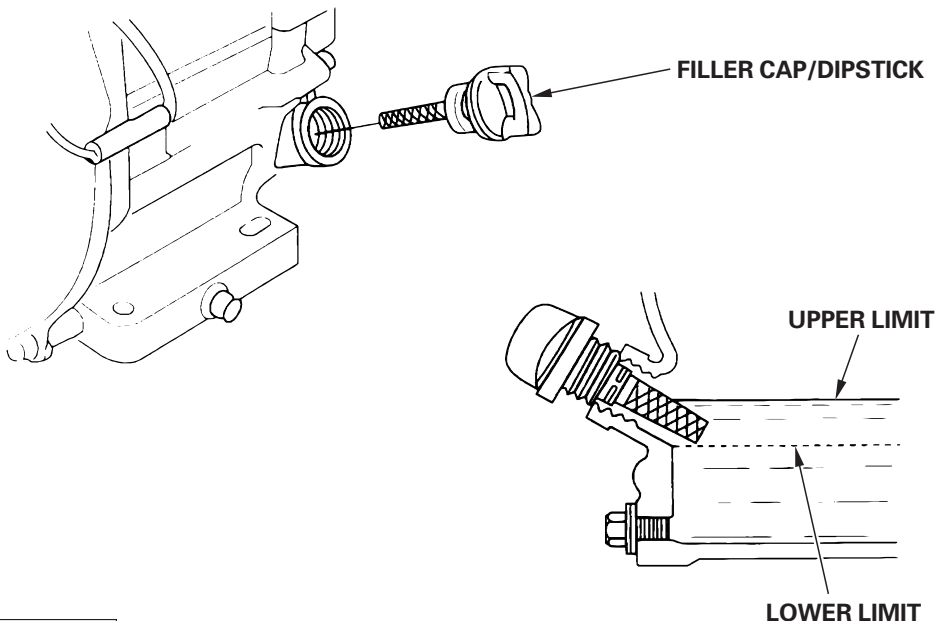

NOTICE

Running the engine with a low oil level can cause engine damage.

The Oil Alert® system (applicable engine types) will automatically stop the engine before the oil level falls below safe limit. However, to avoid the inconvenience of an unexpected shutdown, always check the engine oil level before startup.

SERVICING YOUR ENGINE

ENGINE OIL CHANGE

Drain the used oil while the engine is warm. Warm oil drains quickly and completely.

1. Place a suitable container below the engine to catch the used oil, then remove the filler cap/dipstick, drain plug, and washer.
2. Allow the used oil to drain completely, then reinstall the drain plug, washer, and tighten drain plug securely.
3. Please dispose of used motor oil in a manner that is compatible with the environment. We suggest you take used oil in a sealed container to your local recycling center or service station for reclamation. Do not throw it in the trash, pour it on the ground, or down a drain.
4. With the engine in a level position, fill to the outer edge of the oil filler hole with the recommended oil (see page 28).

NOTICE

Running the engine with a low oil level can cause engine damage.

The Oil Alert® system (applicable engine types) will automatically stop the engine before the oil level falls below the safe limit. However, to avoid the inconvenience of an unexpected shutdown, fill to the upper limit, and check the oil level regularly.

5. Screw in the filler cap/dipstick securely.

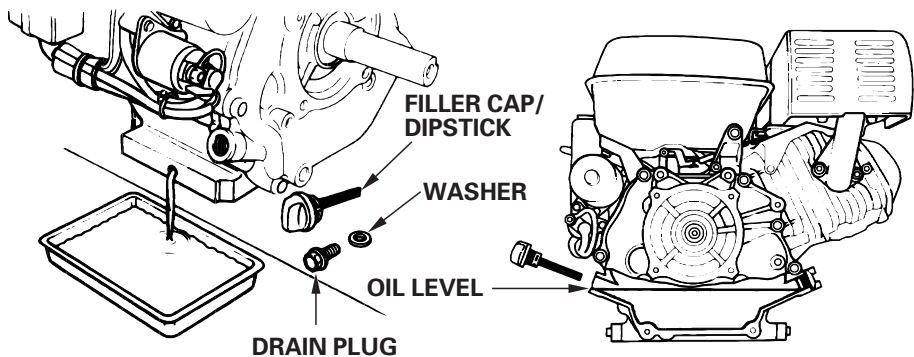

SERVICING YOUR ENGINE

ENGINE OIL RECOMMENDATIONS

Oil is a major factor affecting performance and service life. Use 4-stroke automotive detergent oil.

SAE 10W-30 is recommended for general use. Other viscosities shown in the chart may be used when the average temperature in your area is within the recommended range.

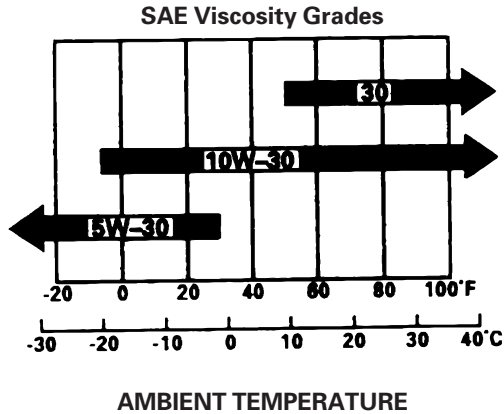

The SAE oil viscosity and service classification are in the API label on the oil container. Honda recommends that you use API SERVICE category SJ or SL oil.

SERVICING YOUR ENGINE

TRANSMISSION OIL LEVEL CHECK (applicable engine types)

Check the transmission oil level with the engine stopped and in a level position.

2 : 1 Reduction Transmission With Centrifugal Clutch

1. Remove the filler cap/dipstick and wipe it clean.
2. Insert and remove the dipstick without screwing it into the filler hole. Check the oil level shown on the dipstick.
3. If the oil level is low, add oil to reach the upper limit mark on the dipstick. Use the same oil that is recommended for the engine (see page 28).
4. Screw in the filler cap/dipstick securely.

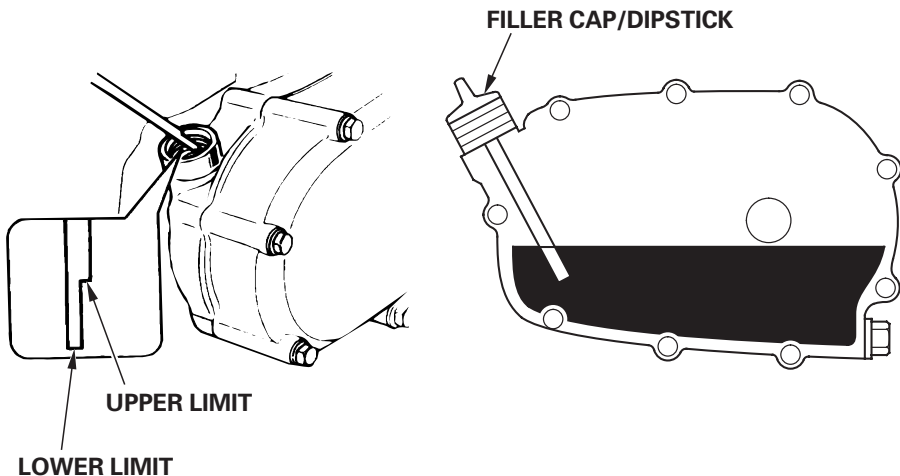

SERVICING YOUR ENGINE

TRANSMISSION OIL CHANGE

(2 : 1 reduction transmission with centrifugal clutch)

Drain the used oil while the engine is warm. Warm oil drains quickly and completely.

1. Place a suitable container below the transmission to catch the used oil, then remove the filler cap/dipstick and the drain plug.
2. Allow the used oil to drain completely, then reinstall the drain plug, and tighten it securely.

Please dispose of used motor oil in a manner that is compatible with the environment. We suggest you take used oil in a sealed container to your local recycling center or service station for reclamation. Do not throw it in the trash, pour it on the ground, or down a drain.

3. With the engine in a level position, fill to the upper limit mark on the dipstick with the same oil that is recommended for the engine (see page 28). To check the oil level, insert and remove the dipstick without screwing it into the filler hole.

Transmission oil capacity: 0.32 US qt (0.30 ℓ)

NOTICE

Running the engine with a low transmission oil level can cause transmission damage.

4. Screw in the filler cap/dipstick securely.

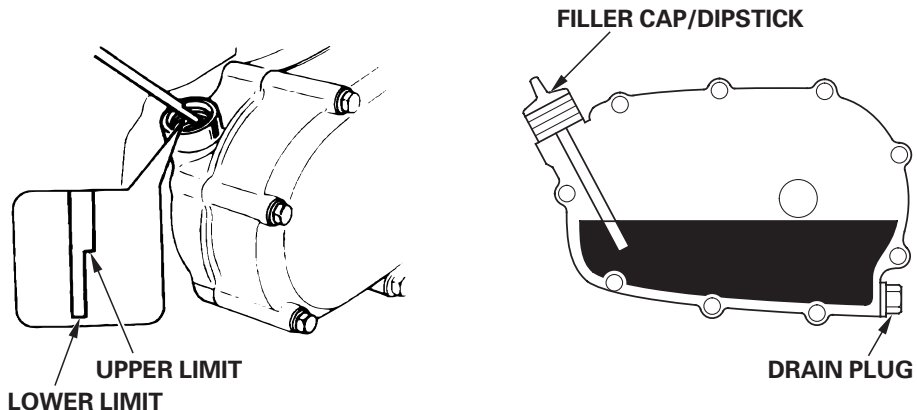

SERVICING YOUR ENGINE

AIR FILTER INSPECTION

Remove the air cleaner cover and inspect the filter. Clean or replace dirty filter elements. Always replace damaged filter elements. If equipped with an oil-bath air cleaner, also check the oil level.

Refer to pages 32–35 for instructions that apply to the air cleaner and filter on your type of engine.

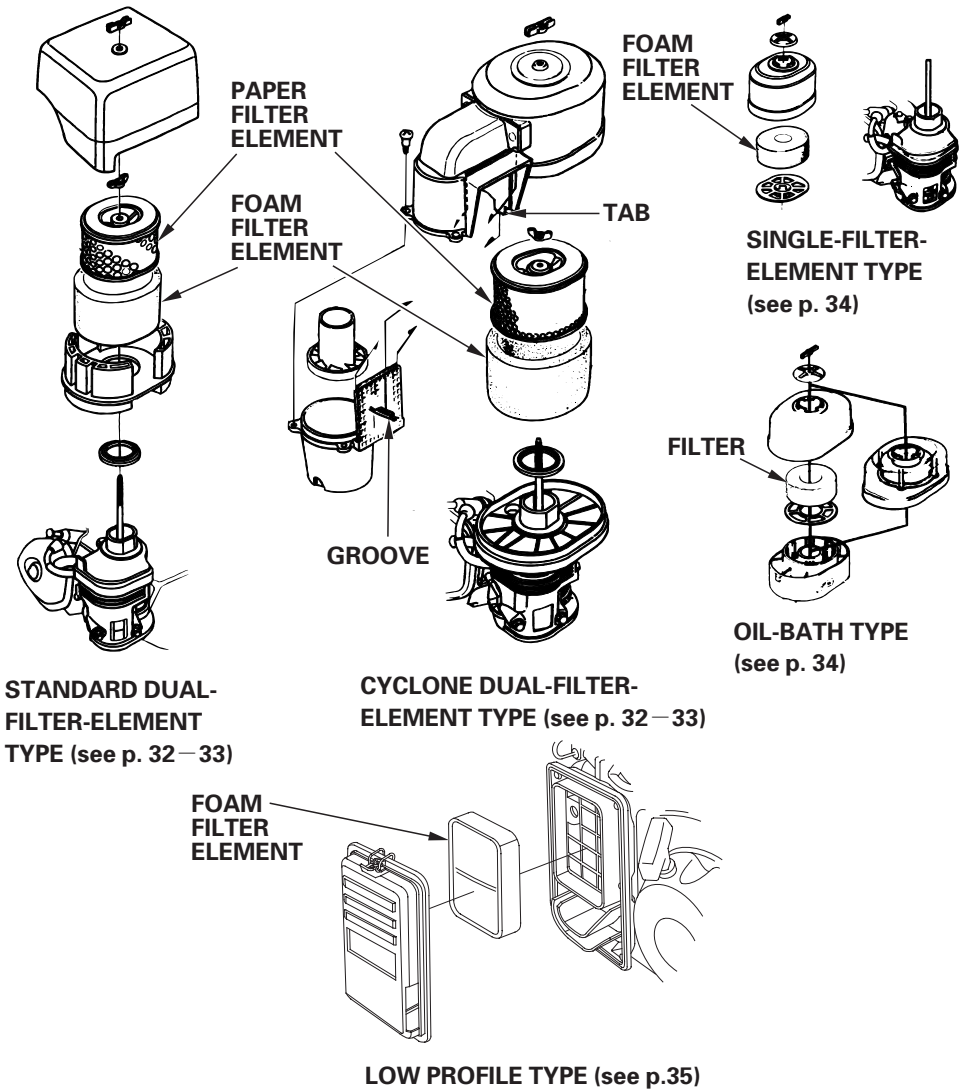

SERVICING YOUR ENGINE

AIR CLEANER SERVICE

A dirty air filter will restrict air flow to the carburetor, reducing engine performance. If you operate the engine in very dusty areas, clean the air filter more often than specified in the MAINTENANCE SCHEDULE.

NOTICE

Operating the engine without an air filter, or with a damaged air filter, will allow dirt to enter the engine, causing rapid engine wear. This type of damage is not covered by the Distributor's Limited Warranty.

Dual-Filter-Element Type

1. Remove the wing nut from the air cleaner cover, and remove the cover.
2. Remove the wing nut from the air filter, and remove the filter.
3. Remove the foam filter from the paper filter.
4. Inspect both air filter elements, and replace them if they are damaged. Always replace the paper air filter element at the scheduled interval (see page 23).
5. Clean the air filter elements if they are to be reused. Refer to following page.

STANDARD DUAL-FILTER-ELEMENT TYPE

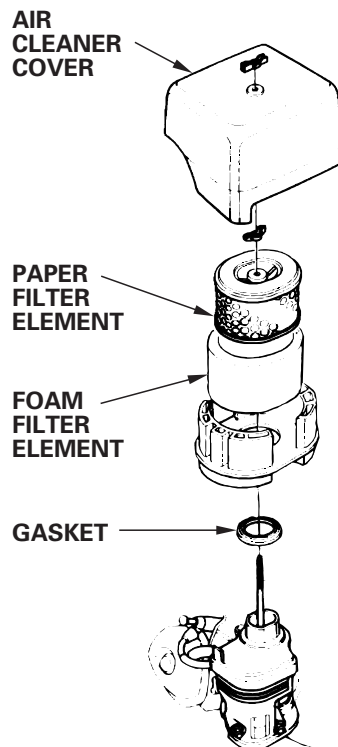

SERVICING YOUR ENGINE

Paper air filter element: Tap the filter element several times on a hard surface to remove dirt, or blow compressed air [not exceeding 30 psi (207 kPa, 2.1 kgf/cm²)] through the filter element from the inside. Never try to brush off dirt; brushing will force dirt into the fibers.

Foam air filter element: Clean in warm soapy water, rinse, and allow to dry thoroughly. Or clean in nonflammable solvent and allow to dry. Dip the filter element in clean engine oil, then squeeze out all excess oil. The engine will smoke when started if too much oil is left in the foam.

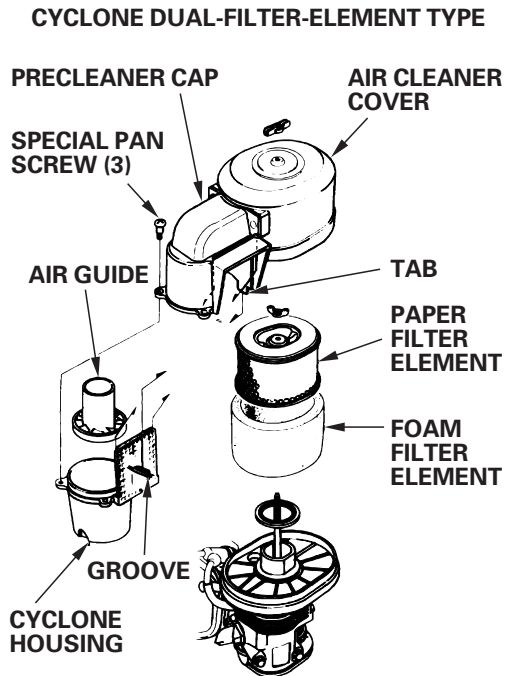

6. **CYCLONE TYPE ONLY:** Remove the three pan-head screws from the precleaner cap, then remove the cyclone housing and air guide. Wash the parts with water, dry them thoroughly, and reassemble them.

Be sure to install the air guide as shown in the illustration.

Install the cyclone housing so the air intake tab fits into the groove in the precleaner cap.

7. Wipe dirt from the inside of the air cleaner base and cover, using a moist rag. Be careful to prevent dirt from entering the air duct that leads to the carburetor.

8. Place the foam air filter element over the paper element, and reinstall the assembled air filter. Be sure the gasket is in place beneath the air filter. Tighten the air filter wing nut securely.

9. Install the air cleaner cover, and tighten the cover wing nut securely.

SERVICING YOUR ENGINE

Oil-Bath & Single-Filter-Element Types

1. Remove the wing nut, and remove the air cleaner cap and cover.
2. Remove the air filter from the cover. Wash the cover and filter in warm, soapy water, rinse, and allow to dry thoroughly. Or clean in nonflammable solvent and allow to dry.
3. Dip the filter in clean engine oil, then squeeze out all excess oil. The engine will smoke if too much oil is left in the foam.
4. OIL BATH TYPE ONLY: Empty the used oil from the air cleaner case, wash out any accumulated dirt with nonflammable solvent, and dry the case.
5. OIL BATH TYPE ONLY: Fill the air cleaner case to the OIL LEVEL mark with the same oil that is recommended for the engine (see page 28).

Oil capacities

GX240/GX270: 2.0 US oz (60 cm³)

GX340/GX390: 2.7 US oz (80 cm³)

6. Reassemble the air cleaner, and tighten the wing nut securely.

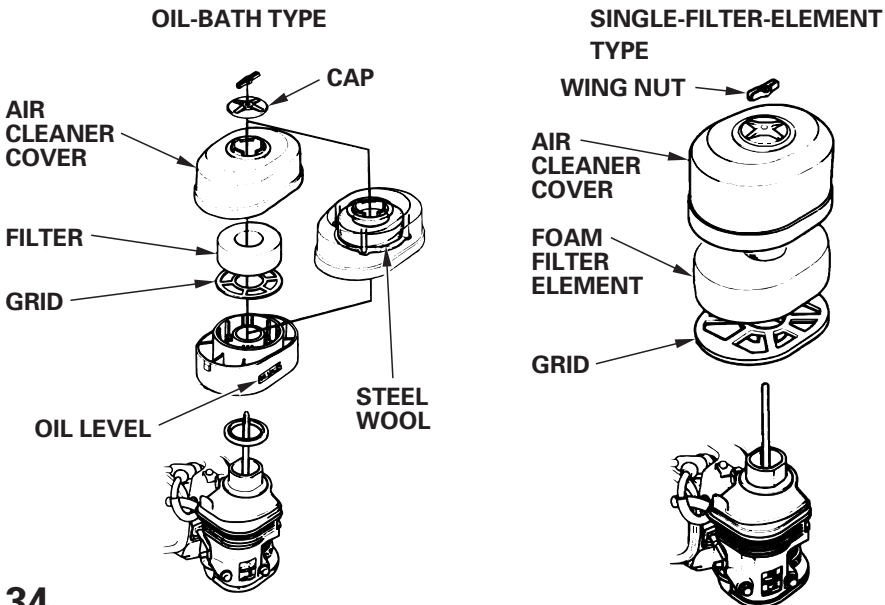

SERVICING YOUR ENGINE

Low Profile Types

1. Unsnap the air cleaner cover clips, remove the air cleaner cover, and remove the element.
2. Wash the air filter in a solution of household detergent and warm water, then rinse thoroughly, or wash in nonflammable or high flashpoint solvent. Allow the air filter to dry thoroughly.
3. Soak the air filter in clean engine oil and squeeze out the excess oil. The engine will smoke during initial startup if too much oil is left in the air filter.
4. Reinstall the air cleaner element and the cover.

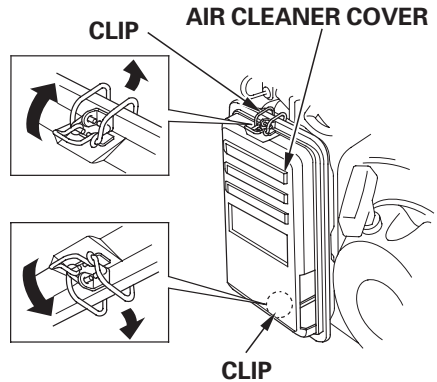

AIR CLEANER ELEMENT

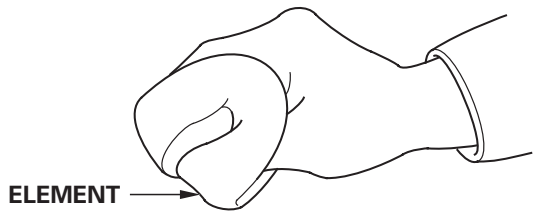
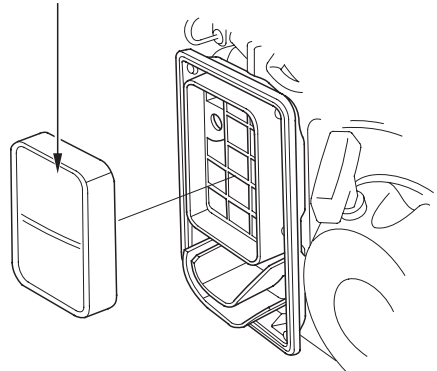

SERVICING YOUR ENGINE

SEDIMENT CUP CLEANING

1. Move the fuel valve to the OFF position, then remove the fuel sediment cup and O-ring.

⚠ WARNING

Gasoline is highly flammable and explosive.

You can be burned or seriously injured when handling fuel.

- Keep heat, sparks and flame away.
- Handle fuel only outdoors.
- Wipe up spills immediately.

2. Wash the sediment cup and O-ring in nonflammable solvent, and dry them thoroughly.
3. Place the O-ring in the fuel valve, and install the sediment cup. Tighten the sediment cup securely.
4. Move the fuel valve to the ON position, and check for leaks. Replace the O-ring if there is any leakage.

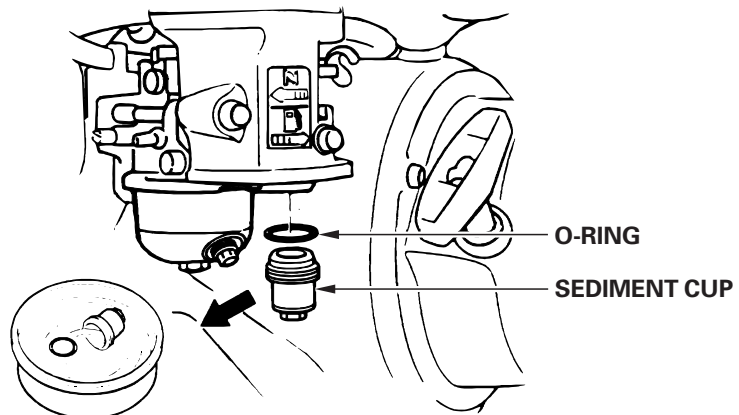

SERVICING YOUR ENGINE

SPARK PLUG SERVICE

Recommended spark plugs: BPR6ES (NGK)
W20EPR-U (DENSO)

NOTICE

An incorrect spark plug can cause engine damage.

1. Disconnect the spark plug cap, and remove any dirt from around the spark plug area.
2. Remove the spark plug with a 13/16-inch spark plug wrench.

SPARK PLUG WRENCH

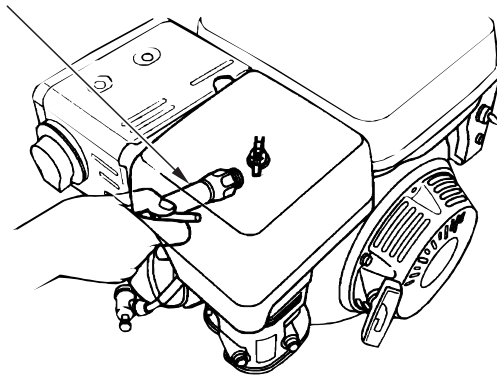

3. Inspect the spark plug. Replace it if the electrodes are worn heavy carbon buildup is found, or if the insulator is cracked or chipped.
4. Measure the spark plug electrode gap with a suitable gauge. The gap should be 0.028 – 0.031 in (0.70 – 0.80 mm). Correct the gap, if necessary, by carefully bending the side electrode.
5. Install the spark plug carefully, by hand, to avoid cross-threading.

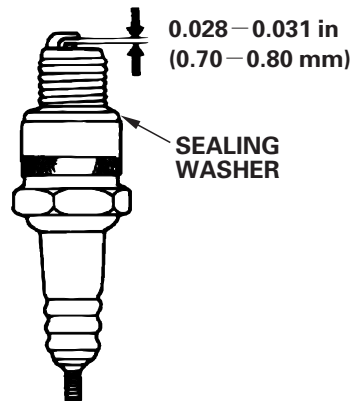

SERVICING YOUR ENGINE

6. After the spark plug seats, tighten with a 13/16-inch spark plug wrench to compress the sealing washer.

If reinstalling the used spark plug, tighten 1/8–1/4 turn after the spark plug seats.

If installing a new spark plug, tighten 1/2 turn after the spark plug seats.

NOTICE

A loose spark plug can overheat and damage the engine. Overtightening the spark plug can damage the threads in the cylinder head.

7. Attach the spark plug cap.

IDLE SPEED ADJUSTMENT

1. Start the engine outdoors, and allow it to warm up to operating temperature.
2. Move the throttle lever to its slowest position.
3. Turn the throttle stop screw to obtain the standard idle speed.

Standard idle speed: 1,400 ± 150 rpm

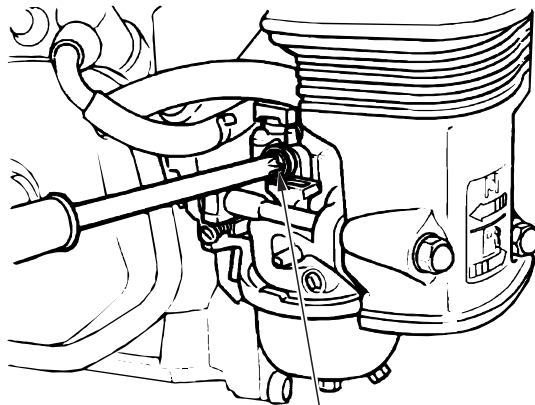

THROTTLE STOP SCREW

SERVICING YOUR ENGINE

SPARK ARRESTER SERVICE (optional equipment)

Your engine is not factory-equipped with a spark arrester. In some areas, it is illegal to operate an engine without a spark arrester. Check local laws and regulations. A spark arrester is available from authorized Honda servicing dealers.

The spark arrester must be serviced every 100 hours to keep it functioning as designed.

If the engine has been running, the muffler will be very hot. Allow the muffler to cool before servicing the spark arrester.

1. Remove the two 8 mm nuts and remove the muffler from the cylinder.
2. Remove the three 4 mm screws from the exhaust deflector, and remove the deflector.
3. Remove the four 5 mm screws from the muffler protector and remove the muffler protector.
4. Remove the 4 mm screws from the spark arrester, and remove the spark arrester from the muffler.

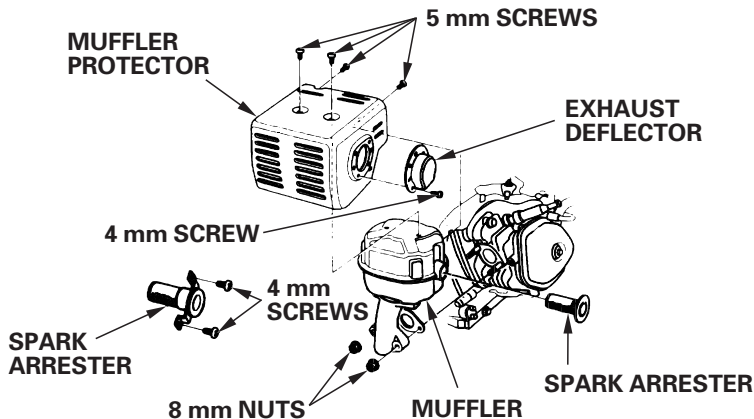

5. Use a brush to remove carbon deposits from the spark arrester screen. Be careful to avoid damaging the screen. The spark arrester must be free of breaks and holes. Replace the spark arrester if it is damaged.

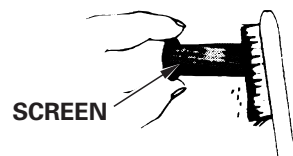

6. Install the spark arrester, muffler protector, exhaust deflector, and muffler in the reverse order of disassembly.

HELPFUL TIPS & SUGGESTIONS

STORING YOUR ENGINE

Storage Preparation

Proper storage preparation is essential for keeping your engine troublefree and looking good. The following steps will help to keep rust and corrosion from impairing your engine's function and appearance, and will make the engine easier to start after storage.

Cleaning

If the engine has been running, allow it to cool for at least half an hour before cleaning. Clean all exterior surfaces, touch up any damaged paint, and coat other areas that may rust with a light film of oil.

NOTICE

- *Using a garden hose or pressure washing equipment can force water into the air cleaner or muffler opening. Water in the air cleaner will soak the air filter, and water that passes through the air filter or muffler can enter the cylinder, causing damage.*
- *Water contacting a hot engine can cause damage. If the engine has been running, allow it to cool for at least half an hour before washing.*

Fuel

Gasoline will oxidize and deteriorate in storage. Old gasoline will cause hard starting, and it leaves gum deposits that clog the fuel system. If the gasoline in your engine deteriorates during storage, you may need to have the carburetor and other fuel system components serviced or replaced.

The length of time that gasoline can be left in your fuel tank and carburetor without causing functional problems will vary with such factors as gasoline blend, your storage temperatures, and whether the fuel tank is partially or completely filled. The air in a partially filled fuel tank promotes fuel deterioration. Very warm storage/temperatures accelerate fuel deterioration. Fuel deterioration problems may occur within a few months, or even less if the gasoline was not fresh when you filled the fuel tank.

HELPFUL TIPS & SUGGESTIONS

The *Distributor's Limited Warranty* does not cover fuel system damage or engine performance problems resulting from neglected storage preparation.

You can extend fuel storage life by adding a fuel stabilizer that is formulated for that purpose, or you can avoid fuel deterioration problems by draining the fuel tank and carburetor.

ADDING A FUEL STABILIZER TO EXTEND FUEL STORAGE LIFE

When adding a fuel stabilizer, fill the fuel tank with fresh gasoline. If only partially filled, air in the tank will promote fuel deterioration during storage. If you keep a container of gasoline for refueling, be sure that it contains only fresh gasoline.

1. Add fuel stabilizer following the manufacturer's instructions.
2. After adding a fuel stabilizer, run the engine outdoors for 10 minutes to be sure that treated gasoline has replaced the untreated gasoline in the carburetor.
3. Stop the engine, and move the fuel valve lever to the OFF position.

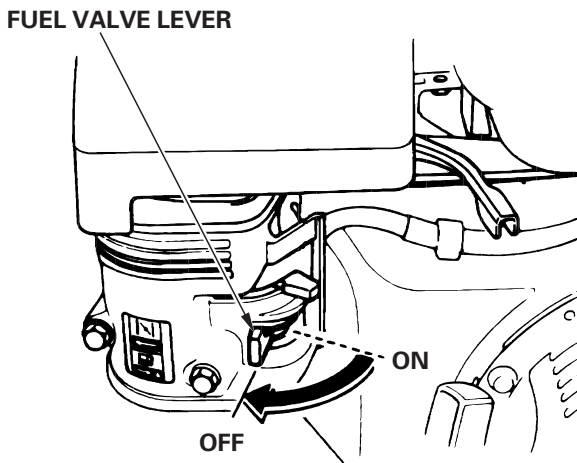

HELPFUL TIPS & SUGGESTIONS

DRAINING THE FUEL TANK AND CARBURETOR

1. Place an approved gasoline container below the carburetor, and use a funnel to avoid spilling fuel.
2. Remove the carburetor drain bolt and sediment cup, then move the fuel valve lever to the ON position.

⚠ WARNING

Gasoline is highly flammable and explosive.

You can be burned or seriously injured when handling fuel.

- Keep heat, sparks and flame away.
- Handle fuel only outdoors.
- Wipe up spills immediately.

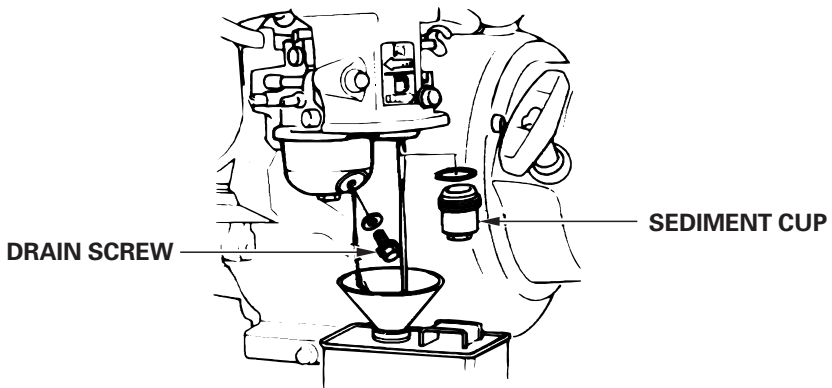

3. After all the fuel has drained into the container, reinstall the drain bolt and sediment cup. Tighten them securely.

HELPFUL TIPS & SUGGESTIONS

Engine Oil

1. Change the engine oil (see page 27).

Engine Cylinder

2. Remove the spark plug (see page 37).
3. Pour a tablespoon (5 – 10 cc) of clean engine oil into the cylinder.
4. Pull the starter rope several times to distribute the oil in the cylinder.
5. Reinstall the spark plug.
6. Pull the starter rope slowly until resistance is felt and the notch on the starter pulley aligns with the hole at the top of the recoil starter cover. This will close the valves so moisture cannot enter the engine cylinder. Return the starter rope gently.

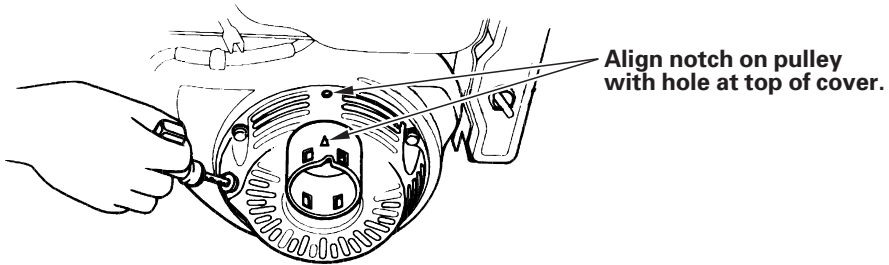

Storage Precautions

If your engine will be stored with gasoline in the fuel tank and carburetor, it is important to reduce the hazard of gasoline vapor ignition. Select a well-ventilated storage area away from any appliance that operates with a flame, such as a furnace, water heater, or clothes dryer. Also avoid any area with a spark-producing electric motor, or where power tools are operated.

If possible, avoid storage areas with high humidity, because that promotes rust and corrosion.

Unless all fuel has been drained from the fuel tank, leave the fuel valve lever in the OFF position to reduce the possibility of fuel leakage.

HELPFUL TIPS & SUGGESTIONS

Position the equipment so the engine is level. Tilting can cause fuel or oil leakage.

With the engine and exhaust system cool, cover the engine to keep out dust. A hot engine and exhaust system can ignite or melt some materials. Do not use sheet plastic as a dust cover. A nonporous cover will trap moisture around the engine, promoting rust and corrosion.

If equipped with a battery for electric starter types, recharge the battery once a month while the engine is in storage. This will help to extend the service life of the battery.

Removal From Storage

Check your engine as described in the *BEFORE OPERATION* chapter of this manual.

If the fuel was drained during storage preparation, fill the tank with fresh gasoline. If you keep a container of gasoline for refueling, be sure that it contains only fresh gasoline. Gasoline oxidizes and deteriorates over time, causing hard starting.

If the cylinder was coated with oil during storage preparation, the engine may smoke briefly at startup. This is normal.

HELPFUL TIPS & SUGGESTIONS

TRANSPORTING

If the engine has been running, allow it to cool for at least 15 minutes before loading the engine-powered equipment on the transport vehicle. A hot engine and exhaust system can burn you and can ignite some materials.

Keep the engine level when transporting to reduce the possibility of fuel leakage. Turn the fuel valve lever to the OFF position.

TAKING CARE OF UNEXPECTED PROBLEMS

ENGINE WILL NOT START	Possible Cause	Correction
1. Electric starting (applicable types): Check battery and fuse.	Battery discharged.	Recharge battery:
	Fuse burnt out.	Replace fuse (p. 47).
2. Check control positions.	Fuel valve OFF.	Move lever to ON.
	Choke OPEN.	Move lever to CLOSED unless engine is warm.
	Engine switch OFF.	Turn engine switch to ON.
3. Check fuel.	Out of fuel.	Refuel (p. 24).
	Bad fuel; engine stored without treating or draining gasoline, or refueled with bad gasoline.	Drain fuel tank and carburetor (p. 42). Refuel with fresh gasoline (p. 24).
4. Remove and inspect spark plug.	Spark plug faulty, fouled, or improperly gapped.	Gap, or replace spark plug (p. 37).
	Spark plug wet with fuel (flooded engine).	Dry and reinstall spark plug. Start engine with throttle lever in FAST position.
5. Take engine to an authorized Honda servicing dealer, or refer to shop manual.	Fuel filter clogged, carburetor malfunction, ignition malfunction, valves stuck, etc.	Replace or repair faulty components as necessary.

ENGINE LACKS POWER	Possible Cause	Correction
1. Check air filter.	Filter element(s) clogged.	Clean or replace filter element(s) (p. 32 – 35).
2. Check fuel.	Bad fuel; engine stored without treating or draining gasoline, or refueled with bad gasoline.	Drain fuel tank and carburetor (p. 42). Refuel with fresh gasoline (p. 24).
3. Take engine to an authorized Honda servicing dealer, or refer to shop manual.	Fuel filter clogged, carburetor malfunction, ignition malfunction, valves stuck, etc.	Replace or repair faulty components as necessary.

TAKING CARE OF UNEXPECTED PROBLEMS

FUSE REPLACEMENT (applicable types only)

The electric starter relay circuit and battery charging circuit are protected by a 5-ampere fuse. If the fuse burns out, the electric starter will not operate. The engine can be started manually if the fuse burns out, but running the engine will not charge the battery.

1. Remove the 6 × 12 mm screw from the rear cover of the engine switch box.
2. Remove the rear cover, and inspect the fuse.

If the fuse is burnt out, remove the fuse cover, then pull out and discard the burnt-out fuse. Install a new 5-ampere fuse, and reinstall the fuse cover.

NOTICE

Never use a fuse with a rating greater than 5 amperes. Serious damage to the electrical system or a fire could result.

3. Reinstall the rear cover. Install the 6 × 12 mm screw and tighten it securely.

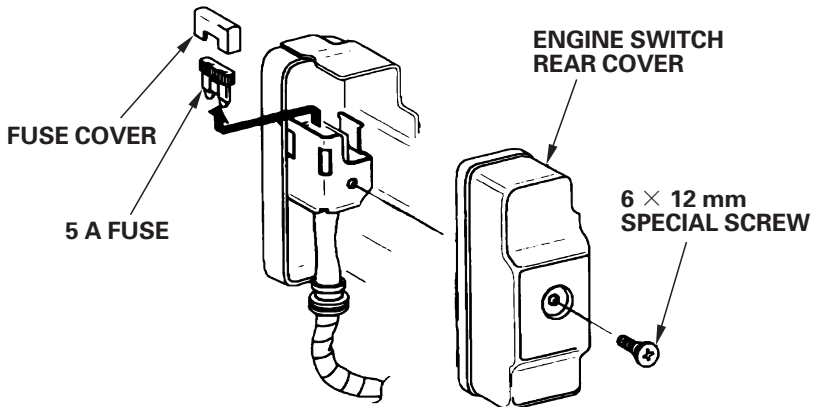

Frequent fuse failure usually indicates a short circuit or an overload in the electrical system. If the fuse burns out frequently, take the engine to a servicing Honda dealer for repair.

TECHNICAL & CONSUMER INFORMATION

TECHNICAL INFORMATION

Serial Number Location

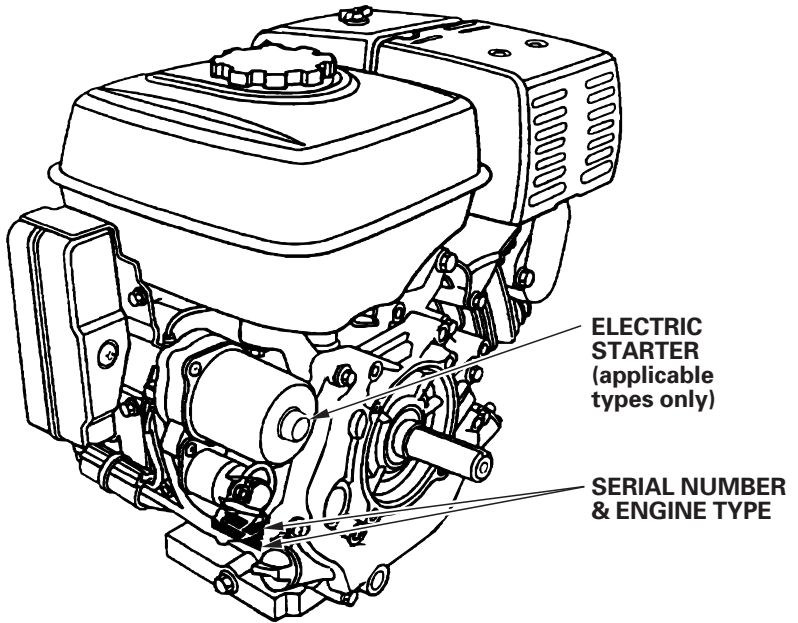

Record the engine serial number in the space below. You will need this serial number when ordering parts, and when making technical or warranty inquiries (see page 60).

Engine serial number: _____

TECHNICAL & CONSUMER INFORMATION

Battery Connections for Electric Starter (applicable types only)

Use a 12-volt battery with an ampere-hour rating of at least 18 Ah.

Be careful not to connect the battery in reverse polarity, as this will short circuit the battery charging system. Always connect the positive (+) battery cable to the battery terminal before connecting the negative (-) battery cable, so your tools cannot cause a short circuit if they touch a grounded part while tightening the positive (+) battery cable end.

⚠ WARNING

A battery can explode if you do not follow the correct procedure, seriously injuring anyone nearby.

Keep all sparks, open flames, and smoking materials away from the battery.

WARNING: Battery posts, terminals and related accessories contain lead and lead compounds. **Wash hands after handling.**

1. Connect the battery positive (+) cable to the starter solenoid terminal as shown.
2. Connect the battery negative (-) cable to an engine mounting bolt, frame bolt, or other good engine ground connection.
3. Connect the battery positive (+) cable to the battery positive (+) terminal as shown.
4. Connect the battery negative (-) cable to the battery negative (-) terminal as shown.
5. Coat the terminals and cable ends with grease.

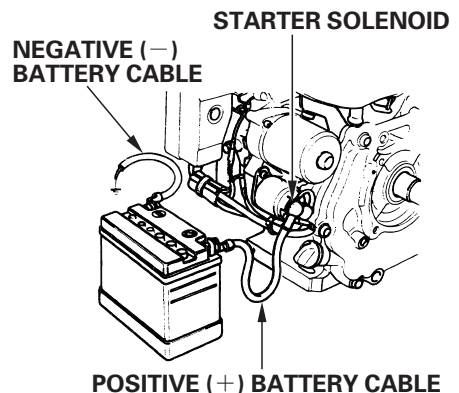

TECHNICAL & CONSUMER INFORMATION

Remote Control Linkage

The throttle and choke control levers are provided with holes for optional cable attachment. The following illustrations show installation examples for a solid wire cable and for a flexible, braided wire cable. If using a flexible, braided wire cable, add a return spring as shown.

It is necessary to loosen the throttle lever friction nut when operating the throttle with a remote-mounted control.

REMOTE THROTTLE LINKAGE

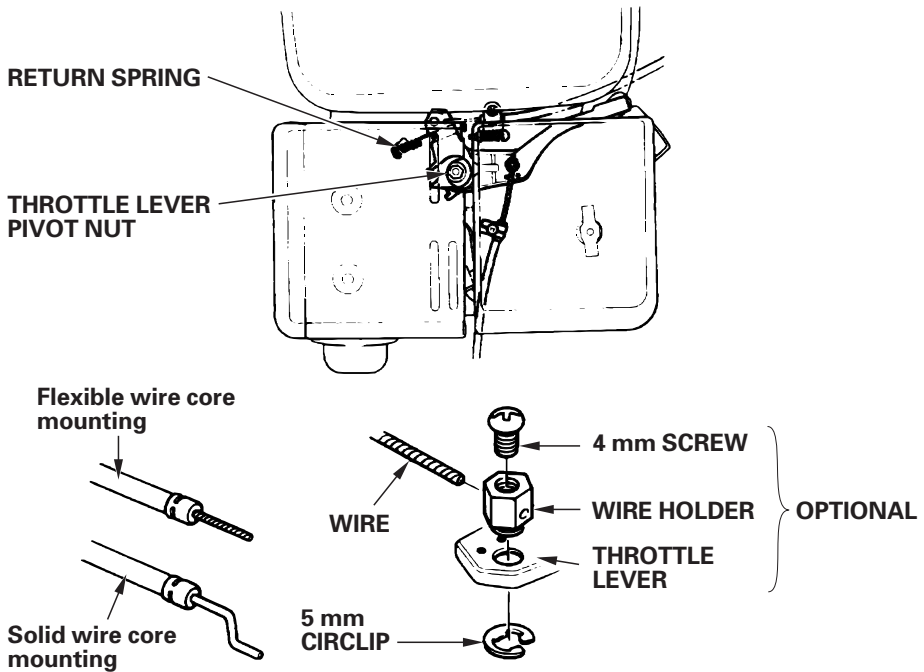

REMOTE CHOKE LINKAGE

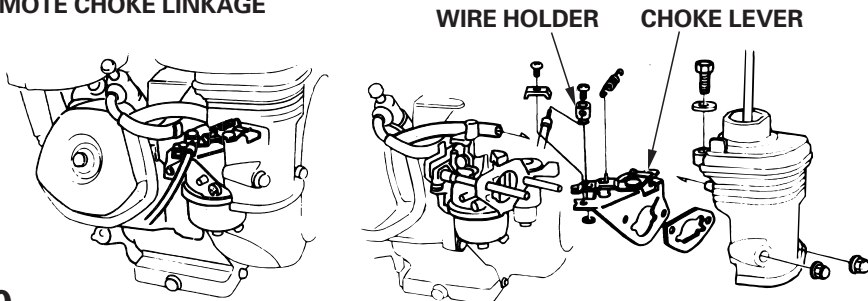

TECHNICAL & CONSUMER INFORMATION

Carburetor Modification for High Altitude Operation

At high altitude, the standard carburetor air-fuel mixture will be too rich. Performance will decrease, and fuel consumption will increase. A very rich mixture will also foul the spark plugs and cause hard starting. Operation at an altitude that differs from that at which this engine was certified, for extended periods of time, may increase emissions.

High altitude performance can be improved by specific modifications to the carburetor. If you always operate your engine at altitudes above 5,000 feet (1,500 meters), have your servicing dealer perform this carburetor modification. This engine, when operated at high altitude with the carburetor modifications for high altitude use, will meet each emission standard throughout its useful life.

Even with carburetor modification, engine horsepower will decrease about 3.5% for each 1,000-foot (300-meter) increase in altitude. The effect of altitude on horsepower will be greater than this if no carburetor modification is made.

NOTICE

When the carburetor has been modified for high altitude operation, the air-fuel mixture will be too lean for low altitude use. Operation at altitudes below 5,000 feet (1,500 meters) with a modified carburetor may cause the engine to overheat and result in serious engine damage. For use at low altitudes, have your servicing dealer return the carburetor to original factory specifications.

TECHNICAL & CONSUMER INFORMATION

Oxygenated Fuels

Some conventional gasolines are being blended with alcohol or an ether compound. These gasolines are collectively referred to as oxygenated fuels.

To meet clean air standards, some areas of the United States and Canada use oxygenated fuels to help reduce emissions.

If you use an oxygenated fuel, be sure it is unleaded and meets the minimum octane rating requirement.

Before using an oxygenated fuel, try to confirm the fuel's contents. Some states/provinces require this information to be posted on the pump.

The following are the EPA approved percentages of oxygenates:

ETHANOL —————(ethyl or grain alcohol) 10% by volume
You may use gasoline containing up to 10% ethanol by volume. Gasoline containing ethanol may be marketed under the name "Gasohol".

MTBE —————(methyl tertiary butyl ether) 15% by volume
You may use gasoline containing up to 15% MTBE by volume.

METHANOL —————(methyl or wood alcohol) 5% by volume
You may use gasoline containing up to 5% methanol by volume, as long as it also contains cosolvents and corrosion inhibitors to protect the fuel system. Gasoline containing more than 5% methanol by volume may cause starting and/or performance problems. It may also damage metal, rubber, and plastic parts of your fuel system.

If you notice any undesirable operating symptoms, try another service station, or switch to another brand of gasoline.

Fuel system damage or performance problems resulting from the use of an oxygenated fuel containing more than the percentages of oxygenates mentioned above are not covered under warranty.

TECHNICAL & CONSUMER INFORMATION

Emission Control System Information

Source of Emissions

The combustion process produces carbon monoxide, oxides of nitrogen, and hydrocarbons. Control of hydrocarbons and oxides of nitrogen is very important because, under certain conditions, they react to form photochemical smog when subjected to sunlight. Carbon monoxide does not react in the same way, but it is toxic.

Honda utilizes lean carburetor settings and other systems to reduce the emissions of carbon monoxide, oxides of nitrogen and hydrocarbons.

The U.S. and California Clean Air Acts

EPA and California regulations require all manufacturers to furnish written instructions describing the operation and maintenance of emission control systems.

The following instructions and procedures must be followed in order to keep the emissions from your Honda engine within the emission standards.

Tampering and Altering

Tampering with or altering the emission control system may increase emissions beyond the legal limit. Among those acts that constitute tampering are:

- Removal or alteration of any part of the intake, fuel or exhaust systems.
- Altering or defeating the governor linkage or speed-adjusting mechanism to cause the engine to operate outside its design parameters.

TECHNICAL & CONSUMER INFORMATION

Problems That May Affect Emissions

If you are aware of any of the following symptoms, have your engine inspected and repaired by your servicing dealer.

- Hard starting or stalling after starting.
- Rough idle.
- Misfiring or backfiring under load.
- Afterburning (backfiring).
- Black exhaust smoke or high fuel consumption.

Replacement Parts

The emission control systems on your Honda engine were designed, built, and certified to conform with EPA and California emission regulations. We recommend the use of genuine Honda parts whenever you have maintenance done. These original-design replacement parts are manufactured to the same standards as the original parts, so you can be confident of their performance. The use of replacement parts that are not of the original design and quality may impair the effectiveness of your emission control system.

A manufacturer of an aftermarket part assumes the responsibility that the part will not adversely affect emission performance. The manufacturer or rebuilder of the part must certify that use of the part will not result in a failure of the engine to comply with emission regulations.

Maintenance

Follow the maintenance schedule on page 23. Remember that this schedule is based on the assumption that your machine will be used for its designed purpose. Sustained high-load or high-temperature operation, or use in unusually wet or dusty conditions, will require more frequent service.

TECHNICAL & CONSUMER INFORMATION

Air Index

An Air Index Information hang tag/label is applied to engines certified to an emission durability time period in accordance with the requirements of the California Air Resources Board.

The bar graph is intended to provide you, our customer, the ability to compare the emissions performance of available engines. The lower the Air Index, the less pollution.

The durability description is intended to provide you with information relating to the engine's emission durability period. The descriptive term indicates the useful-life period for the engine's emission control system. See your *Emission Control Warranty* for additional information.

Descriptive Term	Applicable to Emissions Durability Period
Moderate	50 hours (0 – 65 cc) 125 hours (greater than 65 cc)
Intermediate	125 hours (0 – 65 cc) 250 hours (greater than 65 cc)
Extended	300 hours (0 – 65 cc) 500 hours (greater than 65 cc)

The Air Index Information hang tag must remain on the engine until it is sold. Remove the hang tag before operating the engine.

TECHNICAL & CONSUMER INFORMATION

Specifications

GX240/GX270

Length × Width × Height		14.0 × 16.9 × 16.1 in (355 × 430 × 410 mm)
Dry weight		55.1 lbs (25.0 kg)
Engine type		4-stroke, overhead valve, single cylinder
Displacement [Bore × Stroke]	GX240	14.8 cu-in (242 cm ³) [2.9 × 2.3 in (73 × 58 mm)]
	GX270	16.5 cu-in (270 cm ³) [3.0 × 2.3 in (77 × 58 mm)]
Max. output	GX240	8 bhp (5.9 kW) at 3,600 rpm
	GX270	9 bhp (6.6 kW) at 3,600 rpm
Max. torque	GX240	12.3 lbf-ft (16.7 N·m, 1.7 kgf·m) at 2,500 rpm
	GX270	14.1 lbf-ft (19.1 N·m, 1.95 kgf·m) at 2,500 rpm
Engine oil capacity		1.16 US qt (1.10 ℓ)
Fuel tank capacity		1.59 US gal (6.0 ℓ)
Fuel consumption		0.51 lb/hph (313 g/kWh, 230 g/PSH)
Cooling system		Forced air
Ignition system		Transistorized magneto
PTO shaft rotation		Counterclockwise

GX340/GX390

Length × Width × Height		15.0 × 17.7 × 17.4 in (380 × 450 × 443 mm)
Dry weight		68.3 lbs (31.0 kg)
Engine type		4-stroke, overhead valve, single cylinder
Displacement [Bore × Stroke]	GX340	20.6 cu-in (337 cm ³) [3.2 × 2.5 in (82 × 64 mm)]
	GX390	23.7 cu-in (389 cm ³) [3.5 × 2.5 in (88 × 64 mm)]
Max. output	GX340	11 bhp (8.1 kW) at 3,600 rpm
	GX390	13 bhp (9.6 kW) at 3,600 rpm
Max. torque	GX340	17.4 lbf-ft (23.5 N·m, 2.4 kgf·m) at 2,500 rpm
	GX390	19.5 lbf-ft (26.5 N·m, 2.7 kgf·m) at 2,500 rpm
Engine oil capacity		1.16 US qt (1.10 ℓ)
Fuel tank capacity		1.72 US gal (6.5 ℓ)
Fuel consumption		0.51 lb/hph (313 g/kWh, 230 g/PSH)
Cooling system		Forced air
Ignition system		Transistorized magneto
PTO shaft rotation		Counterclockwise

TECHNICAL & CONSUMER INFORMATION

GX240/GX270/GX340/GX390 Tuneup

ITEM	SPECIFICATION	MAINTENANCE
Spark plug gap	0.028–0.031 in (0.70–0.80 mm)	Refer to page: 37
Idle speed	1,400 ± 150 rpm	Refer to page: 38
Valve clearance	IN: 0.15 ± 0.02 mm (cold) EX: 0.20 ± 0.02 mm (cold)	See your authorized Honda dealer
Other specifications	No other adjustments needed.	

TECHNICAL & CONSUMER INFORMATION

Wiring Diagrams

Oil Alert® and Electric Starter Types

ENGINE SWITCH

	IG	E	ST	BAT
OFF	○	○		
ON				
START			○	○

Bl	BLACK	Gr	GRAY
Y	YELLOW	R	RED
W	WHITE	G	GREEN

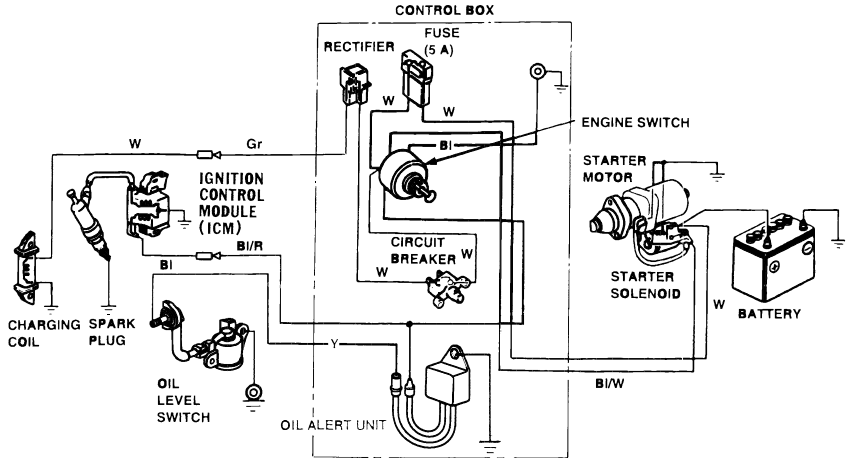

Engine Types With Oil Alert® and Without Electric Starter

Bl	BLACK
Y	YELLOW
G	GREEN

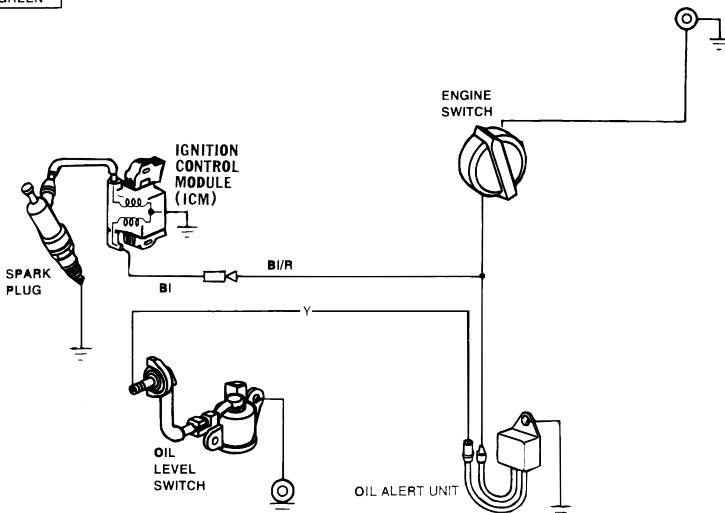

TECHNICAL & CONSUMER INFORMATION

CONSUMER INFORMATION

Honda Publications

These publications will give you additional information for maintaining and repairing your engine. You may order them from your Honda engine dealer.

Shop Manual

This manual covers complete maintenance and overhaul procedures. It is intended to be used by a skilled technician.

Parts Catalog

This manual provides complete, illustrated parts lists.

TECHNICAL & CONSUMER INFORMATION

Warranty Service Information

Servicing dealership personnel are trained professionals. They should be able to answer any questions you may have. If you encounter a problem that your dealer does not solve to your satisfaction, please discuss it with the dealership's management. The Service Manager, General Manager, or Owner can help. Almost all problems are solved in this way.

If you are dissatisfied with the decision made by the dealership's management, contact the Honda Regional Engine Distributor for your area. You can find their name, address, and phone number using the dealer/distributor locator on our website at (www.honda-engines.com) or by calling 1-800-426-7701.

If you are still dissatisfied after speaking with the Regional Engine Distributor, you may contact the Honda Power Equipment Customer Relations Office. You can write to:

American Honda Motor Co., Inc.
Power Equipment Division
Customer Relations Office
4900 Marconi Drive
Alpharetta, Georgia 30005-8847

Or telephone: (770) 497-6400

When you write or call, please give us this information:

- Equipment manufacturer's name and model number that the engine is mounted on
- Engine model and serial number (see page 48)
- Name of dealer who sold the engine to you
- Name, address, and contact person of dealer who services your engine
- Name of Distributor you contacted and the contact person
- Date of purchase
- Your name, address and telephone number
- A detailed description of the problem

QUICK REFERENCE INFORMATION

Fuel	Type	Unleaded gasoline with a pump octane rating of 86 or higher (page 25).
Engine Oil	Type	SAE 10W-30, API SJ or SL, for general use (page 28)
Spark Plug	Type	NGK: BPR6ES, DENSO: W20EPR-U
	Gap	0.028 – 0.031 in (0.70 – 0.80 mm) (page 37)
Carburetor	Idle speed	1,400 ± 150 rpm (page 38)
Maintenance	Before each use	Check engine oil level. Check transmission oil level if applicable. Check air filter.
	First 20 hours	Change engine oil. Change transmission oil if applicable.
	Subsequent	Refer to the maintenance schedule on page 23.

HONDA

The Power of Dreams

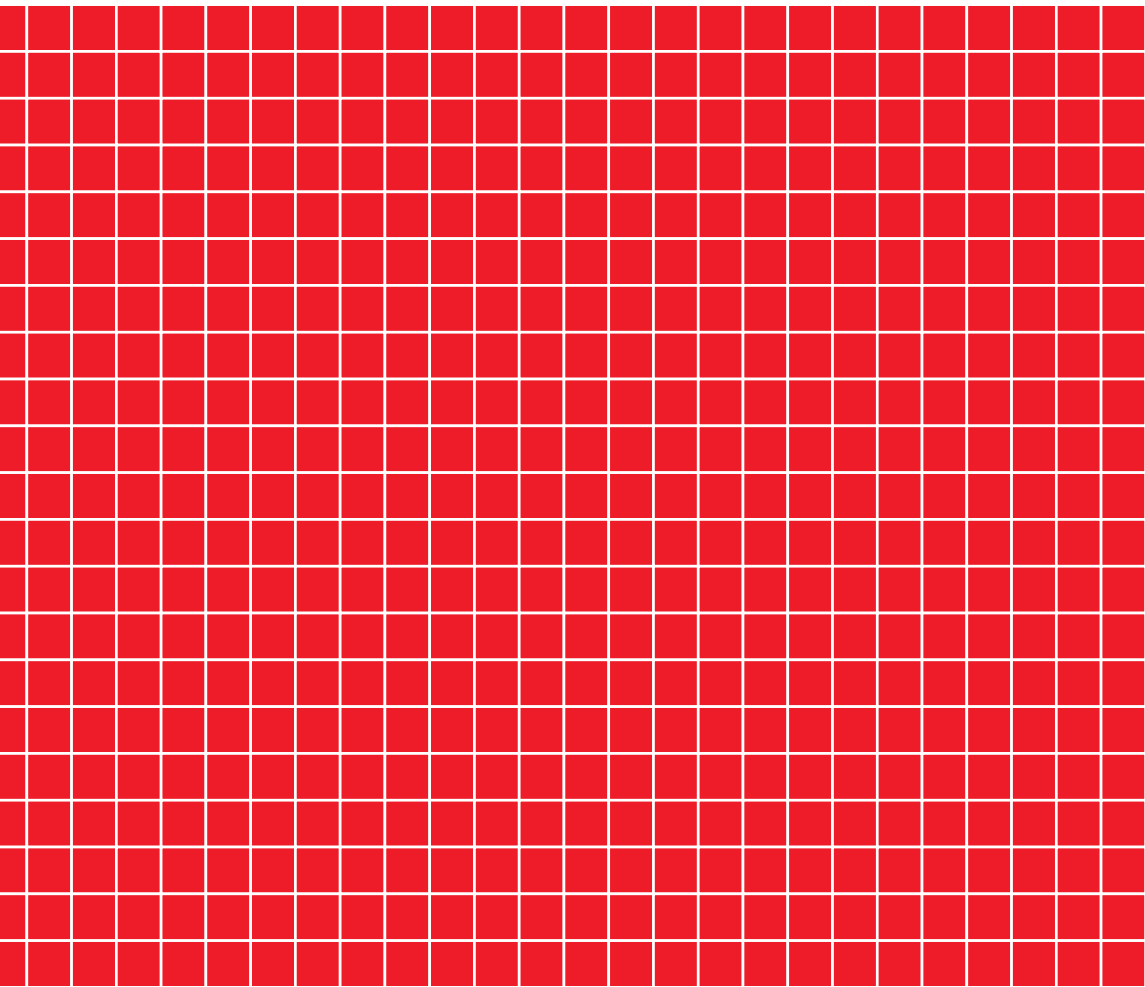

31ZH9621
00X31-ZH9-6210

EM3 K1 (AH) (英) (Y) (HC) 50000.2003.10
Printed in Japan